

RESIDENTIAL DRIVEWAY APPROACH

HARD SURFACE (HMA/CONC) DETAIL SHEET

LAPEER COUNTY ROAD COMMISSION
820 Davis Lake Road, Lapeer, MI 48446
Phone: 810-664-6272 www.lcrconline.com

Permit Notes:

1. If an existing gravel (aggregate) driveway approach is upgraded to hard surface, **ALL approach standards shall be met.**
2. It is the Applicant's responsibility to ensure that the entire driveway approach is constructed on the Property Owner's frontage.
 - a. Do not encroach upon the neighboring property without written permission.
3. The driveway approach location shall be approved by the LCRC prior to obtaining any building permits.
4. Call Miss Dig (811) prior to digging.
5. All disturbed areas within the Right of Way (R/W) must be restored with seed and mulch blanket prior to final approval of the permit.
6. All mailboxes must meet the federal standards. Refer to the LCRC Mailbox Policy available on our website at www.lcrconline.com. Brick / Stone or other hazardous mailboxes are prohibited.
7. No other hazardous items such as large rocks, landscaping, or fences are permitted in the Road Right of Way. Existing rocks or other hazardous items shall be removed prior to final approval.
8. **This Permit is valid for 90 days unless otherwise noted. All Work shall be completed within 90 days.**
9. **All Concrete Forms shall be inspected for compliance prior to concrete pour. Contact LCRC office a minimum of 24 hrs prior to concrete pour to schedule a form inspection. Do not place concrete until form approval is received.**

Driveway Approach Dimensions

1. At a minimum, the driveway approach shall meet the dimensions in **Figure 1**.
2. Regardless of construction method used, the approach shall be surfaced to the extent of these minimum dimensions.
3. Edges of hard surface driveway approach shall be backfilled within the Right of Way to eliminate the edge drop. Refer to Item 3 in *Driveway Approach Material Section*.
4. Hard Surface Driveway Approach shall NOT be placed within 5-ft of the edge of a Gravel (Aggregate) County Road.
5. Hard Surface Approaches proposed adjacent to a Hard Surface County Road:
 - a. All concrete driveway approaches shall use a felt construction joint unless approved otherwise.
 - b. Existing pavement shall be saw cut to facilitate the joint.

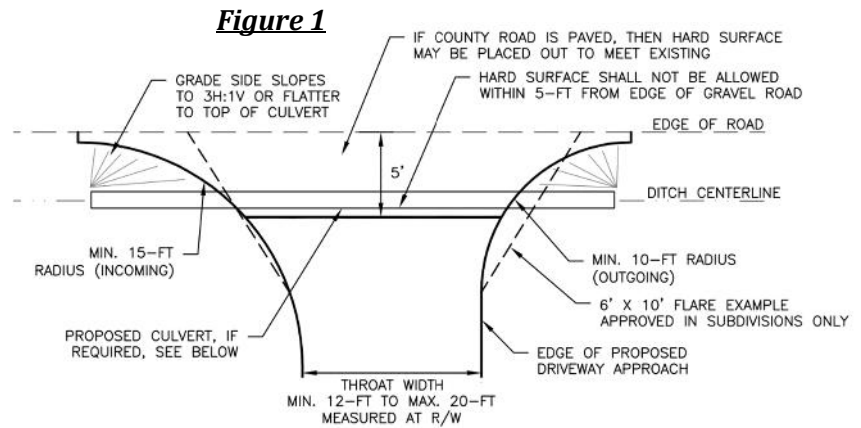

Driveway Approach Depths

1. Asphalt (HMA) material shall be minimum 4-inches in depth over minimum 6-inches compacted Gravel (Aggregate) Base.
2. Concrete material shall be minimum 6-inches in depth over minimum 6-inches of either compacted Class II (Sand) material or compacted Gravel (Aggregate) Base.

Driveway Approach Material

1. Asphalt material shall meet the Michigan Department of Transportation (MDOT) specifications for HMA Mixture 36A or 13A.
2. Concrete shall meet the MDOT specifications for 3,500 psi, P1, 6 sack material
3. Gravel (Aggregate) Base or Shoulder material shall meet the MDOT gradation requirements of 21AA, 22A or 23A.
 - a. Aggregate Material may be natural aggregate, limestone, crushed concrete or HMA millings.
 - b. Approach Shoulder material may also be topsoil when located outside of the influence of the road shoulder.
 - c. However, absolutely no Aggregate Base or Shoulder material may be larger than 1.5-inches in diameter, and shall be free of foreign material, brick, wire, glass, wood, or rubber. If material is found to not meet the gradation or material requirements, approach will be rejected.
4. The Lapeer County Road Commission shall not be responsible for damaged or removed stamped concrete and asphalt or other pavement designs within the Road Right of Way.
 - a. If necessary, the Lapeer County Road Commission shall only replace such pavements with *basic* asphalt or concrete material.
 - b. These decorative type pavements are placed at the Applicant/Land Owner's own financial risk.

Driveway Approach Grade

1. Driveway Approaches shall be a minimum 2% slope down / away from the road so that water runs away from the road and toward the ditch line, as shown in **Figure 2**.
2. In no case shall water from the driveway drain out onto the shoulder or roadway.

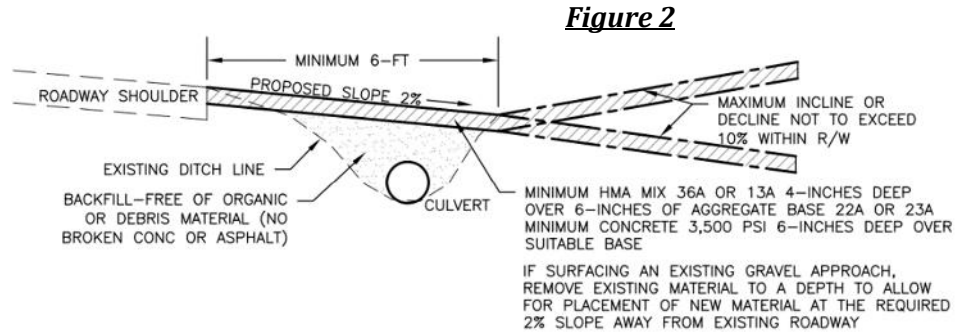

Sight Distance

1. It is necessary to provide a clear line of sight to safely enter or exit the roadway. All trees, brush, bushes, banks and objects (rocks, fences, landscaping) in the shaded portion of **Figure 3** shall be cleared / removed so that the ground is fairly level and allows for proper sight distance.
2. Minimum sight distance for a Residential Driveway Approach shall be in accordance with **Table 1** below.

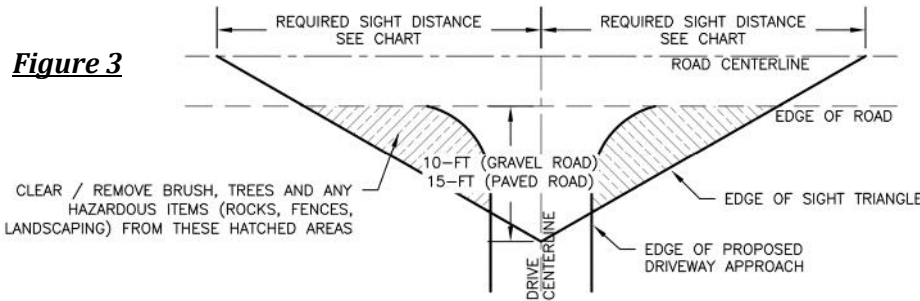

Table 1

Speed Limit (MPH)	Minimum Sight Distance (Feet)
25	280
30	335
35	390
40	445
45	500
50	555
55 / Unposted	610

Culvert Length and Side Slopes

1. Driveway Approach culverts shall be installed in line with the road ditch.
2. The Contractor shall ensure that the culvert grade allows positive flow through the ditch.
 - a. Ditch elevation may need to be adjusted (daylighted) to allow for positive flow.
3. Vegetative growth and topsoil shall be removed prior to culvert placement.
4. A separate permit is required for enclosure of the ditch beyond the adjacent limits of the driveway approach culvert.
5. Driveway Approach and culvert shall not be located or placed in such a manner that they interfere with cross-culvert drainage.

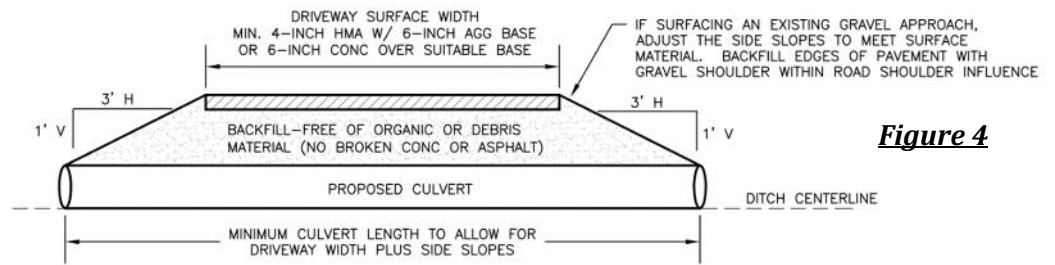

Figure 4

- a. If a cross culvert is located near the proposed approach, maintain a minimum of 10-ft between inverts, or as directed by the LCRC Engineer.
6. The required culvert length is dependent on the ditch depth, location and size of driveway approach width selected.
 - a. The minimum culvert length is 30-ft and works well in most cases.
 - b. A 3-ft horizontal to 1-ft vertical slope is required from the driveway aggregate edge down to the top of the culvert. Therefore, a longer culvert may be required in some cases, as shown in **Figure 4**.
 - c. Under no circumstances shall a vertical headwall be placed. No rocks, stone or headwall shall be placed around the culvert. Engineered or manufactured sloped end sections are allowable.

7. Culvert material shall meet the requirements of **Table 2**.

Table 2

Material	Diameter Size (Inches)	Minimum Gauge / Thickness
Corrugated Steel or Metal Pipe (CSP / CMP)	12-inch to 24-inch	16 gauge
	30-inch to 42-inch	14 gauge
	48-inch and greater	12 gauge
Reinforced Concrete Pipe (RCP)	12-inch to 48-inch	Minimum Class II (AASHTO M170)
Smooth Lined Corrugated Plastic Pipe Dual Wall (SLCPP)	12-inch to 24-inch	AASHTO M294, Type S Prior Approval is Required
	30-inch and greater	Prior Approval is Required

- a. Use of Corrugated Plastic Pipe within the R/W requires prior approval by the LCRC Engineer, refer to the *Placement of Plastic Pipe Under Driveways* Policy for additional requirements.
- b. All joints shall be soil tight.